

Self-priming centrifugal pumps for water supplies (even if mixed with gas) in small household systems, connected to autoclave tanks, for transferring liquids and emptying tanks; also used for gardening.



CAM 50N÷140



CAM 150÷300



Construction features

Pump body	cast iron
Motor bracket	aluminum (50N÷140) cast iron (150÷300)
Impeller	Noryl®, brass AISI 304, Noryl®, brass (100N÷140)
Mechanical seal	ceramic-graphite-NBR
Motor shaft	stainless steel AISI 416
Liquid temperature	0 - 50 °C
Operating pressure	max 6 bar (50N÷75N) max 7 bar (100N÷140) max 8 bar (150÷300)

Motor

	3- 230/400V - 50Hz
2 Poles induction motor	1- 230V - 50Hz (with thermal protection)
Insulation class	F
Protection degree	IPX4

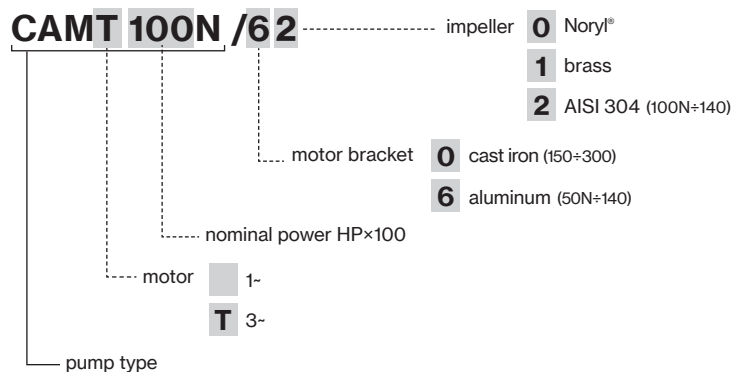
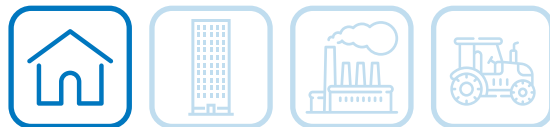

TYPE	LOTS			
	TRUCK		CONTAINER	
	PALLET (cm)	N° pumps	PALLET (cm)	N° pumps
CAM 50N÷140	85×110×145	60	85×110×190	80
			80×120×190	64
CAM 150÷300	80×120×145	35	80×120×180	49

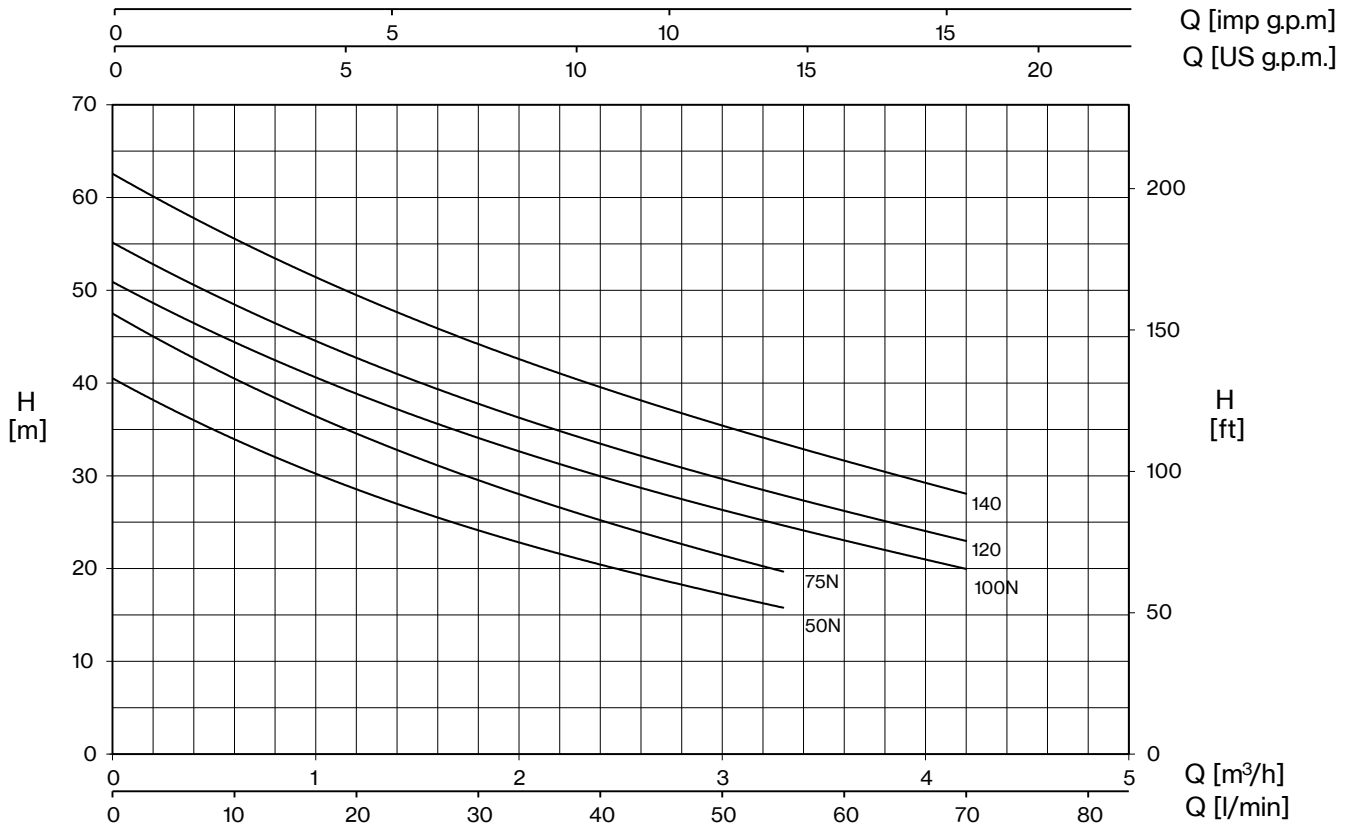

TYPE		P2		P1 (kW)		AMPERE		Q (m³/h - l/min)								
1~	3~	HP	kW	1~	3~	1~ 230V 50 Hz	3~ 400V 50 Hz	0	0,6	1,2	1,8	2,4	3	3,3	3,6	4,2
								0	10	20	30	40	50	55	60	70
								H (m)								
CAM 50N	CAMT 50N	0,6	0,44	0,7	0,67	3,1	1,3	40,5	34,0	28,5	24,1	20,5	17,2	15,8		
CAM 75N	CAMT 75N	0,8	0,59	0,82	0,78	3,6	1,4	47,5	40,5	34,5	29,6	25,2	21,4	19,7		
CAM 100N	CAMT 100N	1	0,74	1,04	0,92	4,7	1,7	50,9	44,3	38,9	34,1	30,1	26,3	24,6	23,0	20,0
CAM 120	CAMT 120	1,2	0,88	1,14	1,07	5,2	1,9	55,1	48,5	42,6	37,8	33,5	29,7	27,9	26,2	23,0
CAM 140	CAMT 140	1,5	1,1	1,3	1,25	6,0	2,5	62,5	55,7	49,4	44,2	39,5	35,5	33,5	31,6	28,1

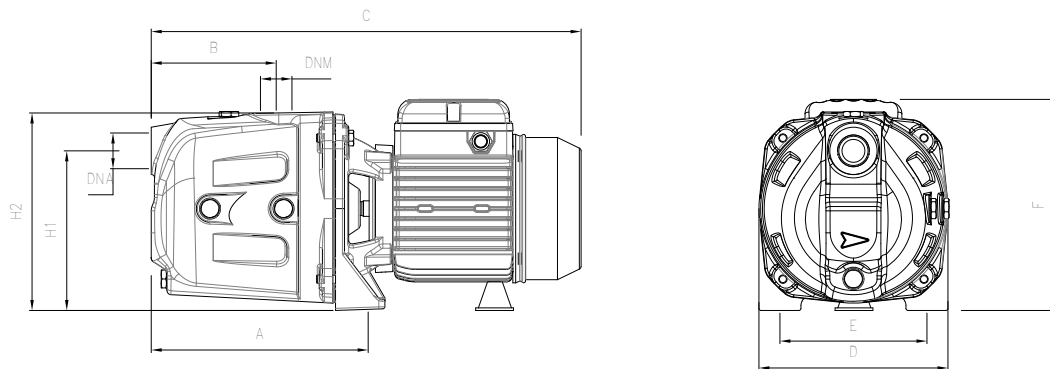

TYPE	DIMENSIONS (mm)													Kg
	A	B	C	D	E	F	H1	H2	DNA	DNM	I	L	M	
CAM 50N	214	119	410	180	140	195	150	185			440	194	215	12
CAM 75N	214	119	410	180	140	195	150	185			440	194	215	12,5
CAM 100N	214	119	410	180	140	195	150	185	1" G	1" G	440	194	215	14
CAM 120	214	119	410	180	140	195	150	185			440	194	215	14,5
CAM 140	214	119	410	180	140	195	150	185			440	194	215	15



CAM

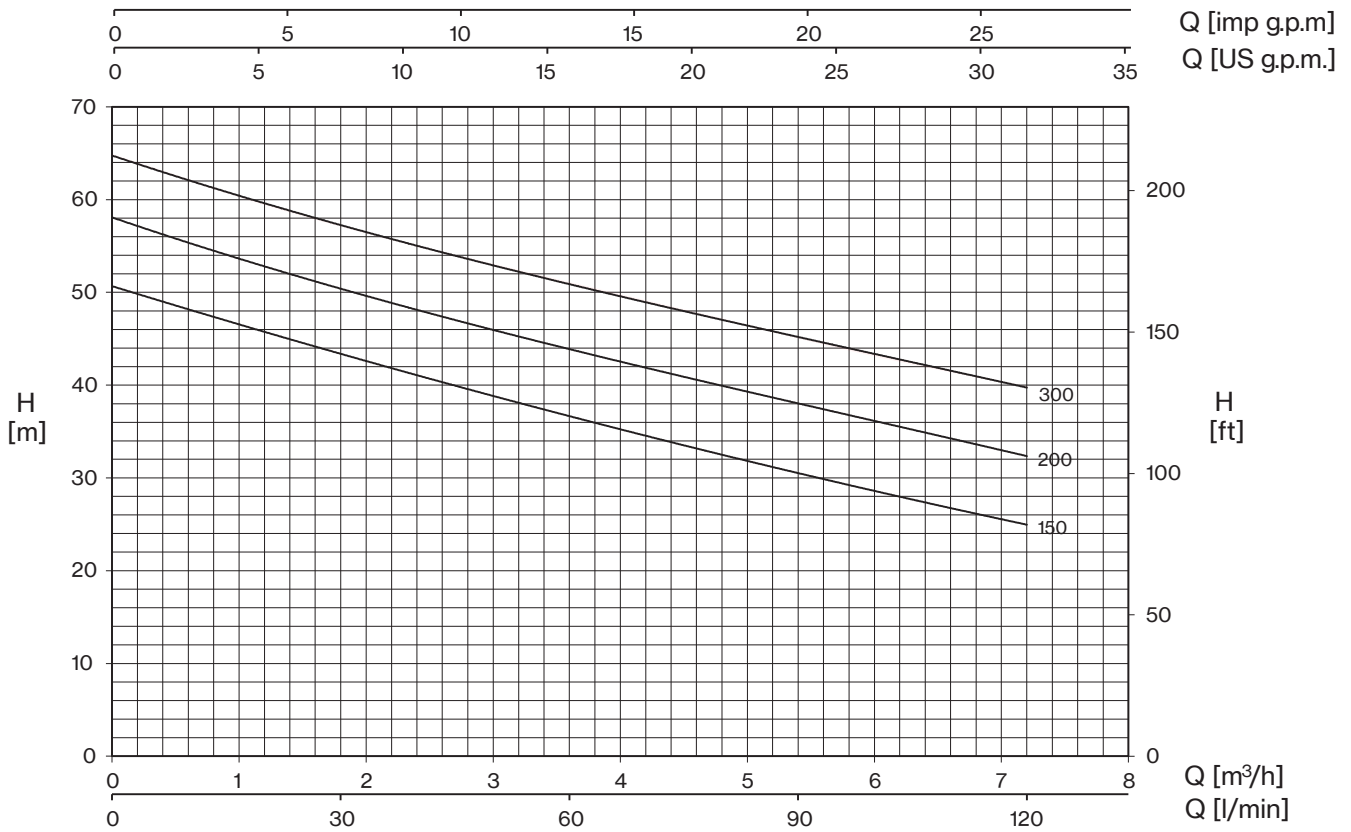

TYPE		P2		P1 (kW)		AMPERE		Q (m³/h - l/min)						
1~	3~	HP	kW	1~	3~	1~ 230V 50 Hz	3~ 400V 50 Hz	0	1,2	2,4	3,6	4,8	6	7,2
								0	20	40	60	80	100	120
								H (m)						
CAM 150	CAMT 150	1,5	1,1	1,9	1,8	8,2	3,4	50,7	45,7	41,0	36,8	32,5	28,5	25,0
CAM 200	CAMT 200	2	1,5	2,2	2,1	9,8	3,9	58,1	52,8	48,0	44,0	40,0	36,0	32,4
-	CAMT 300	3	2,2	-	2,5	-	4,8	64,8	59,5	55,0	51,0	47,1	43,2	39,8

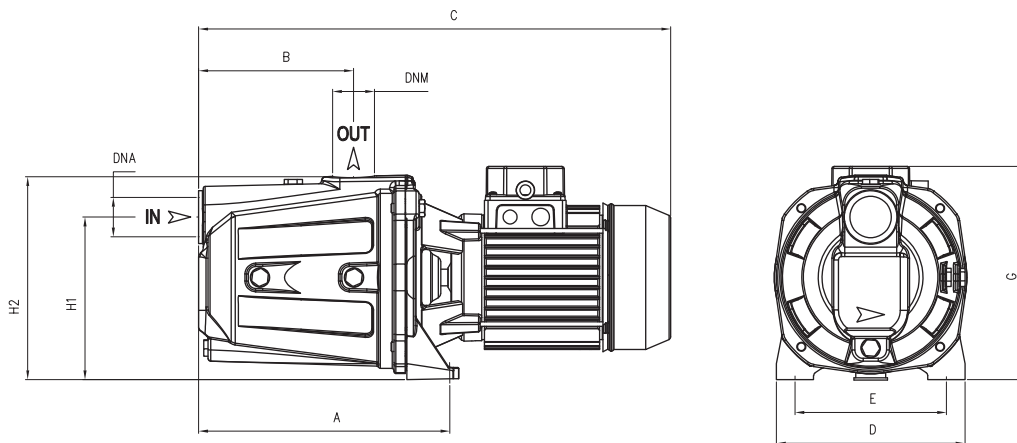

TYPE	DIMENSIONS (mm)														Kg
	A	B	C	D	E	F	G	H1	H2	DNA	DNM	I	L	M	
CAM 150	269,6	167	506	203	165	220	231,5	175	220	1" ½ G	1" ¼ G	535	235	230	26
CAM 200	269,6	167	506	203	165	220	231,5	175	220	1" ½ G	1" ¼ G	535	235	230	27
CAM 300	269,6	167	506	203	165	220	231,5	175	220	1" ½ G	1" ¼ G	535	235	230	26,5



CAM (Garden version)

Portable electropumps complete with handle, cable with plug and switch.
The performances depend on adopted pump type.

TYPE	P2		P1 (kW)	Pipe		Performance	
	HP	kW		Suction ("G)	Delivery ("G)	Q (l/min)	H (m)
CAM 50N	0,6	0,44	0,7	1	1	10-55	34,0-15,8
CAM 75N	0,8	0,59	0,82	1	1	10-55	40,5-19,7
CAM 100N	1	0,74	1,04	1	1	10-70	44,3-20,0
CAM 120	1,2	0,88	1,14	1	1	10-70	48,5-23
CAM 140	1,5	1,1	1,3	1	1	10-70	55,7-28,1

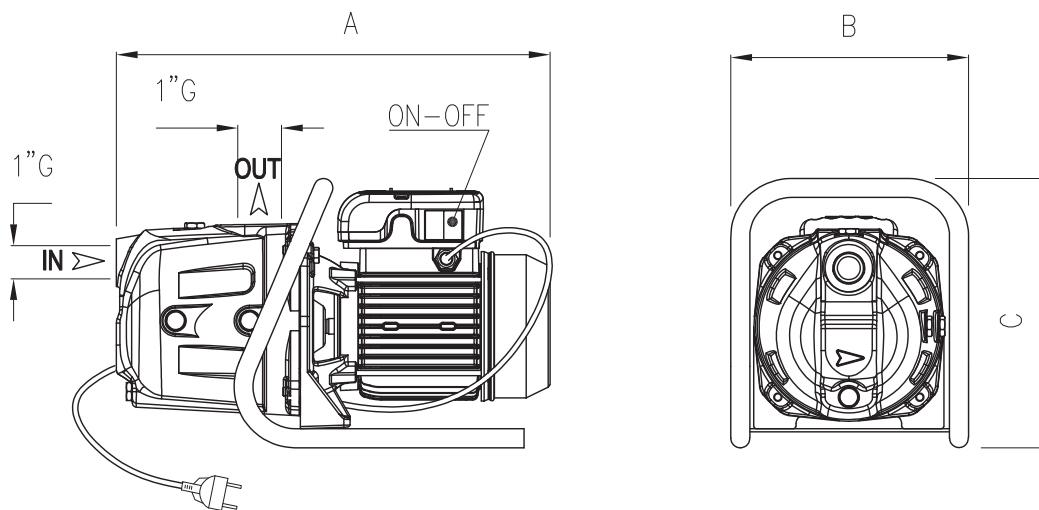

TYPE	DIMENSIONS (mm)		
	A	B	C
CAM 50N	410	266	252
CAM 75N	410	266	252
CAM 100N	410	266	252
CAM 120	410	266	252
CAM 140	410	266	252