



# MB



## GENERALITÀ / FEATURES

Elettropompe centrifughe bigirante in ghisa adatte alla pressurizzazione di impianti domestici, piccola irrigazione, movimentazione di liquidi non aggressivi ad uso civile ed industriale.

*2 impellers centrifugal pumps made of cast-iron, suitable to boost domestic systems, small irrigation, pumping of non-aggressive liquids for civil and industrial use.*

## MATERIALI / MATERIALS

- Corpo pompa e supporto in ghisa
  - Albero: acciaio inox AISI 303
  - Giranti e diffusore: Noryl®
  - Tenuta meccanica: ceramica-grafite
- 
- *Pump body and motor bracket: cast iron*
  - *Shaft: stainless steel AISI 303*
  - *Impellers and diffuser: Noryl®*
  - *Ceramic graphite mechanical seal*

## MOTORE / MOTOR

- Motore chiuso autoventilato
  - Grado di protezione: IP44
  - Isolamento: classe F
  - Alimentazione monofase 230V-50Hz, con protezione termica
  - Alimentazione trifase 230/400V-50Hz
- 
- *Closed self-ventilated motor*
  - *Protection degree: IP44*
  - *Insulation class F*
  - *Single-phase feeding 230V-50Hz, with motor protection*
  - *Three-phase feeding 230/400V-50Hz*

## LIMITI DI IMPIEGO / OPERATING CONDITIONS

- Pressione max: 8 bar
  - Temperatura max acqua: 50°C
- 
- *Max. pressure: 8 bar*
  - *Water temperature max: 50°C*



ELETTROPOMPE CENTRIFUGHE BIGIRANTI  
TWO IMPELLERS CENTRIFUGAL ELECTRIC PUMPS

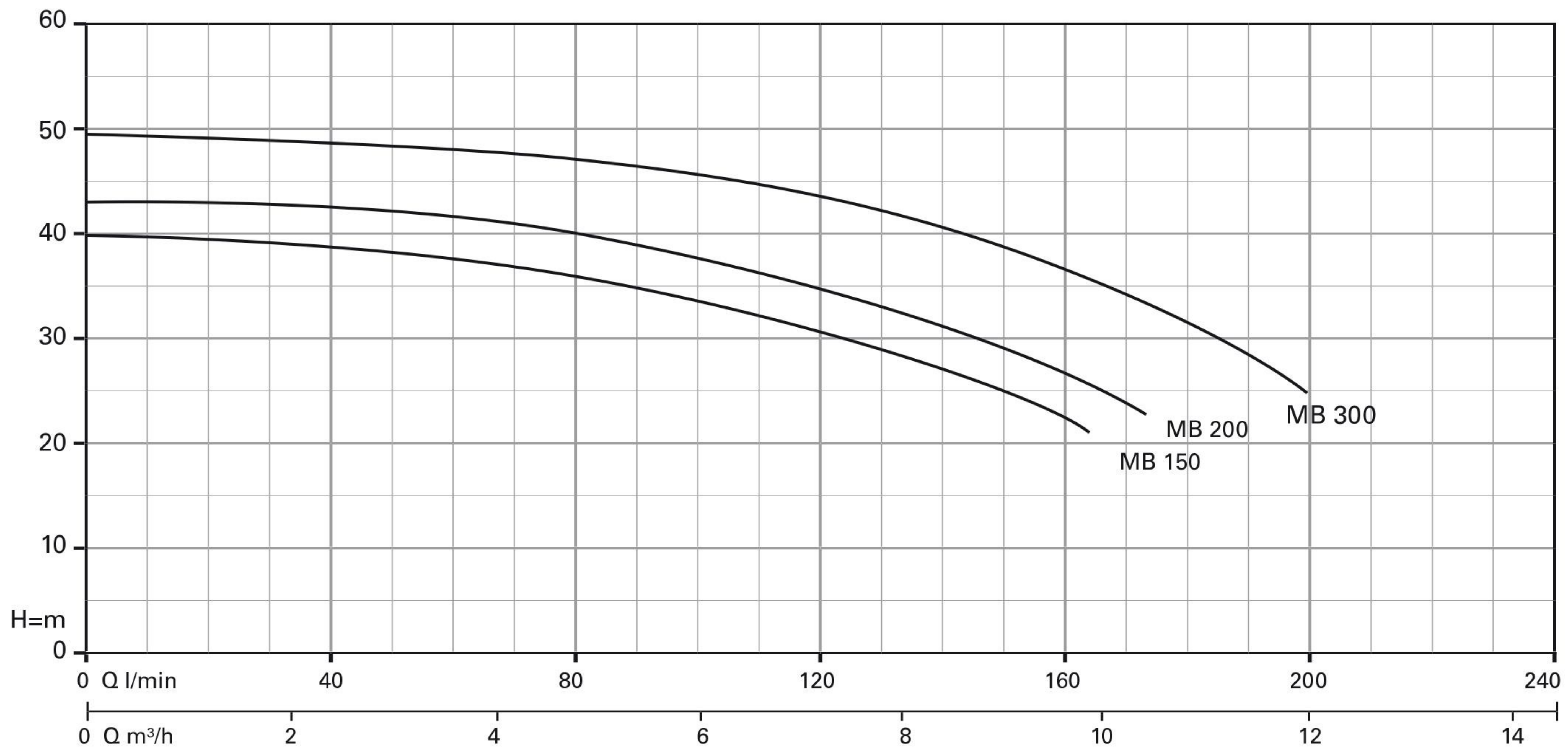

CARATTERISTICHE TECNICHE A 2900 GIRI / TECHNICAL PERFORMANCE AT 2900 RPM

Modello Model		P2		A		Q=Portata - Capacity					
1~	3~	HP	kW	1x230V	3x400V	m³/h 0	2,4	4,8	7,2	9,6	12
						l/min 0	40	80	120	160	200
						Prevalenza manometrica totale in m C.A. Total head in meters w.c.					
MB 150	MBT 150	1,5	1,1	7,7	2,9	39,5	38,5	36	30,8	22	
MB 200	MBT 200	2	1,5	9,5	3,6	43	42,1	39,5	34,5	26	
MB 300	MBT 300	3	2,2	11,8	4,8	49	48,4	47,2	43,6	36,5	46,5

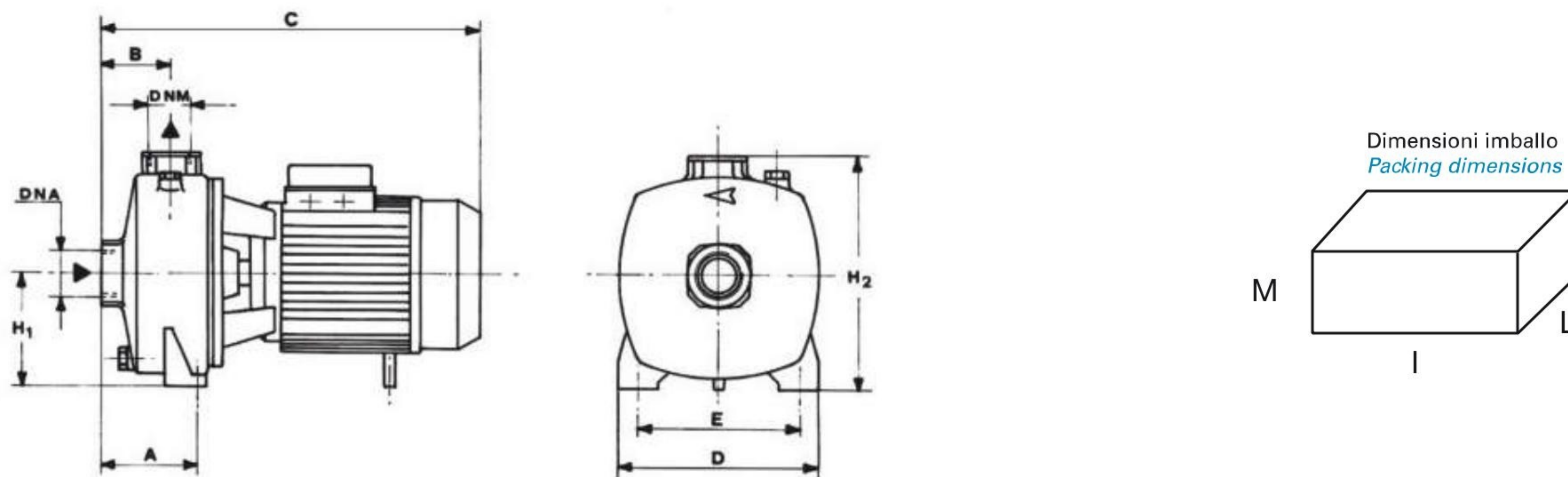

MODELLO POMPA PUMP'S MODEL	DIMENSIONI POMPA mm PUMP'S DIMENSIONS mm									DIMENSIONI IMBALLO mm PACKING DIMENSIONS mm			PESO WEIGHT kg
	A	B	C	D	E	H1	H2	DNA	DNM	I	L	M	
MB 150	108	73	385	205	165	115	242	1" 1/2 G	1" 1/4 G	405	225	295	21,2
MB 200	108	73	385	205	165	115	242	1" 1/2 G	1" 1/4 G	405	225	295	21,7
MB 300	108	73	385	205	165	115	242	1" 1/2 G	1" 1/4 G	405	225	295	21,7