

# CR



## GENERALITÀ / FEATURES

Pompa centrifuga a girante aperta indicata per servizi che richiedono portate relativamente medio-basse. La girante aperta consente inoltre il passaggio di eventuali corpi solidi aventi dimensioni inferiori a 10 mm.

*Open impeller centrifugal electric pump suitable for high deliveries and medium-low heads: the open impeller allows passing of eventual solids, size of which is less than 10mm.*

## MATERIALI / MATERIALS

- Corpo pompa e supporto in ghisa
  - Albero: acciaio inox AISI 416
  - Girante: Noryl® (ottone su richiesta)
  - Tenuta meccanica: ceramica-grafite
- 
- *Pump body and motor bracket: cast iron*
  - *Shaft: stainless steel AISI 416*
  - *Impeller: Noryl® (brass on request)*
  - *Ceramic graphite mechanical seal*

## MOTORE / MOTOR

- Motore chiuso autoventilato
  - Grado di protezione: IP44
  - Isolamento: classe F
  - Alimentazione monofase 230V-50Hz, con protezione termica
  - Alimentazione trifase 230/400V-50Hz
- 
- *Closed self-ventilated motor*
  - *Protection degree: IP44*
  - *Insulation class F*
  - *Single-phase feeding 230V-50Hz, with motor protection*
  - *Three-phase feeding 230/400V-50Hz*

## LIMITI DI IMPIEGO / OPERATING CONDITIONS

- Pressione max: 6 bar
  - Temperatura max acqua: 50°C
- 
- *Max. pressure: 6 bar*
  - *Max. water temperature: 50°C*



ELETTROPOMPE CENTRIFUGHE GIRANTE APERTA  
OPEN IMPELLER CENTRIFUGAL ELECTRIC PUMPS

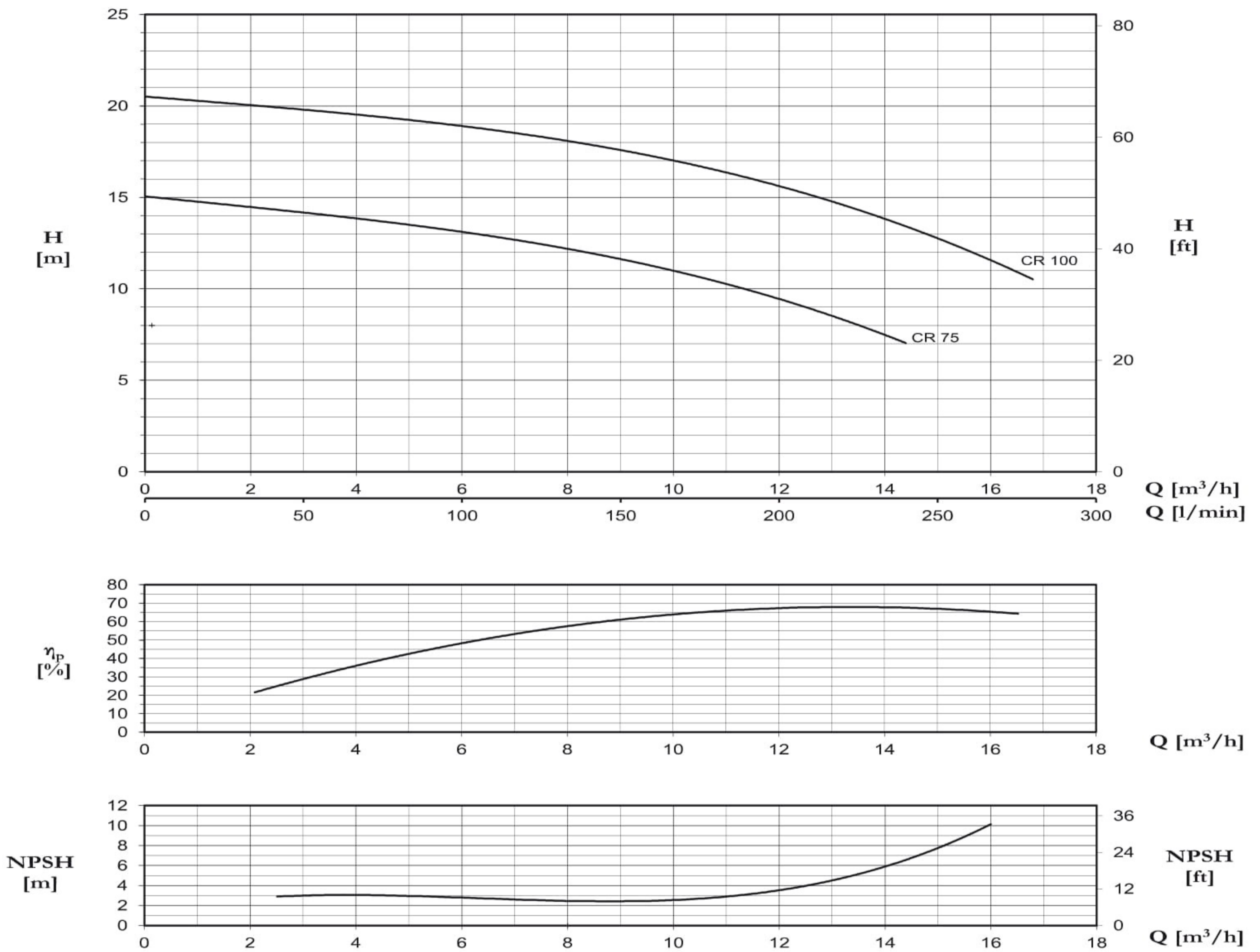

CARATTERISTICHE TECNICHE A 2900 GIRI / TECHNICAL PERFORMANCE AT 2900 RPM

Modello Model		P2		A		Q=Portata - Capacity						
1~	3~	HP	kW	1x230V	1x400V	m³/h 0	3	6	9	12	14,4	16,8
						l/min 0	50	100	150	200	240	280
Prevalenza manometrica totale in m C.A. Total head in meters w.c.												
CR 75	CRT 75	0,8	0,59	3,4	1,5	15	14,3	13	11,6	9,5	7	
CR 100	CRT 100	1	0,75	5,3	2,4	20,5	19,8	18,9	17,7	15,5	13,5	10,5

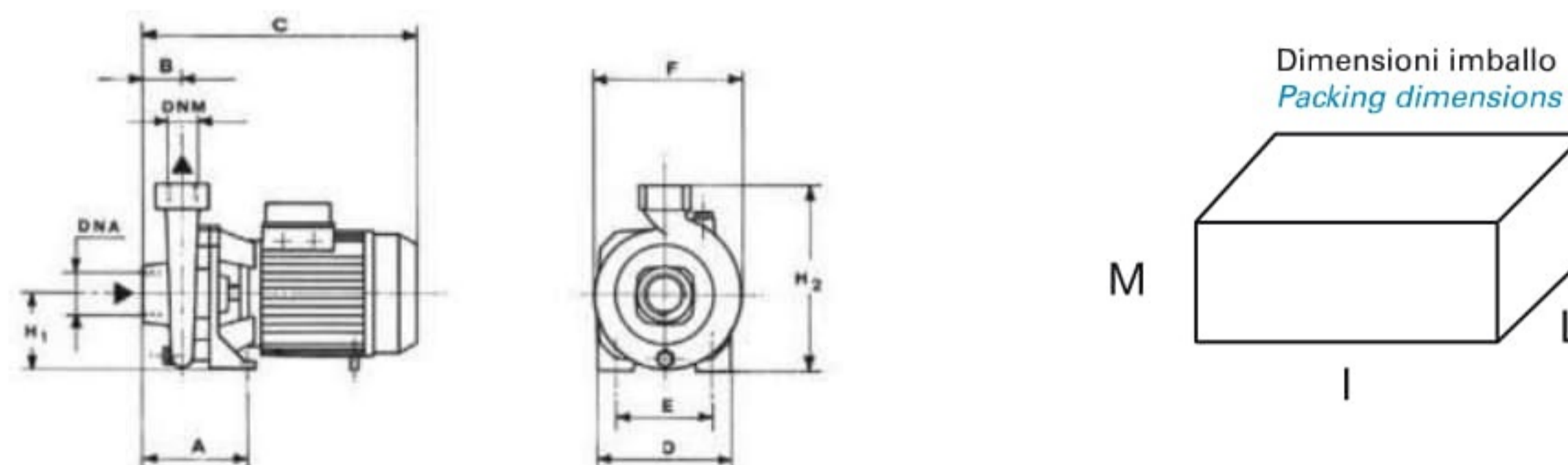

MODELLO POMPA PUMP'S MODEL	DIMENSIONI POMPA mm PUMP'S DIMENSIONS mm										DIMENSIONI IMBALLO mm PACKING DIMENSIONS mm			PESO WEIGHT kg
	A	B	C	D	E	F	H1	H2	DNA	DNM	I	L	M	
CR 75/ CRT 75	120	45	308	155	115	170	97	222	1" 1/2 G	1" 1/4 G	325	200	265	12,2
CR 100/ CRT 100	120	45	308	155	115	170	97	222	1" 1/2 G	1" 1/4 G	325	200	265	13,5

CATALOGO GENERALE GENERAL CATALOGUE 2019 51